

OPTIturn[®] TU 2506 / TU 2506V

Leading spindle lathes with feed gear for demanding users.

TU 2506V with brushless motor for continuously variable speed control

Facts that impress in terms of quality, performance and price

- ▶ Precision workmanship
- ▶ Powerful motor, low-maintenance motor
- ▶ Ribbed grey cast steel prism bed with strong ribbing, induction tempered and precision ground
- ▶ Tempered and polished z-axis guideway
- ▶ Guaranteed concentricity of spindle nose better than 0.009 mm
- ▶ Automatic longitudinal/leading spindle drive
- ▶ Roll-milled trapezoidal spindles
- ▶ Chip guard on top slide
- ▶ Top slide displaceable on cross slide
- ▶ Leading spindle for thread tapping or automatic longitudinal turning
- ▶ Quadruple tool holder
- ▶ All guides adjustable using cleats
- ▶ Concentricity at chuck better than 0.04 mm
- ▶ Right-handed/left-handed rotation switchable via control panel
- ▶ Tempered main spindle borne on adjustable precision taper roller bearings
- ▶ Tapered roller bearings in P5 quality
- ▶ Tempered spindle nose with \varnothing 26 mm spindle bore
- ▶ Tailstock adjustable \pm 5 mm for turning spheres
- ▶ Tailstock spindle sleeve and handwheel with adjustable fine scaling 0.02 mm
- ▶ Fast, easy adjustment of the tailstock without tools thanks to clamping lever
- ▶ Leading spindle borne on two sintered bearings
- ▶ Handwheels on slide with adjustable fine scaling 0.04 / 0.01 mm
- ▶ Thrust bearings
- ▶ Emergency stop button
- ▶ Three-jaw lathe chuck included in standard scope of delivery
- ▶ Interchangeable gears in standard scope of delivery for thread tapping
- ▶ Fully equipped; the user can immediately start productive work after commissioning

TU 2506 V

- ▶ Smooth action, powerful, brushless DC drive with excellent control characteristics
- ▶ High-precision steel chuck for higher speeds
- ▶ Speed change easily adjustable via potentiometer
- ▶ Digital speed display

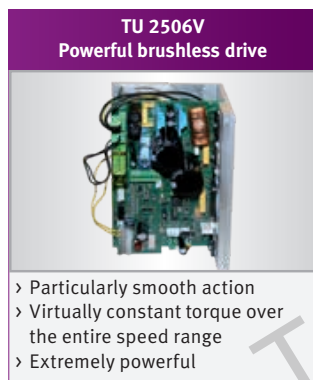

Accessories

Machine chassis

Art. no. 3440409

Vibration dampers machine base SE 1

(6 pcs. needed)

Art. no. 3381012

Levelling platen SE 55

(6 pcs. needed)

Art. no. 3352981

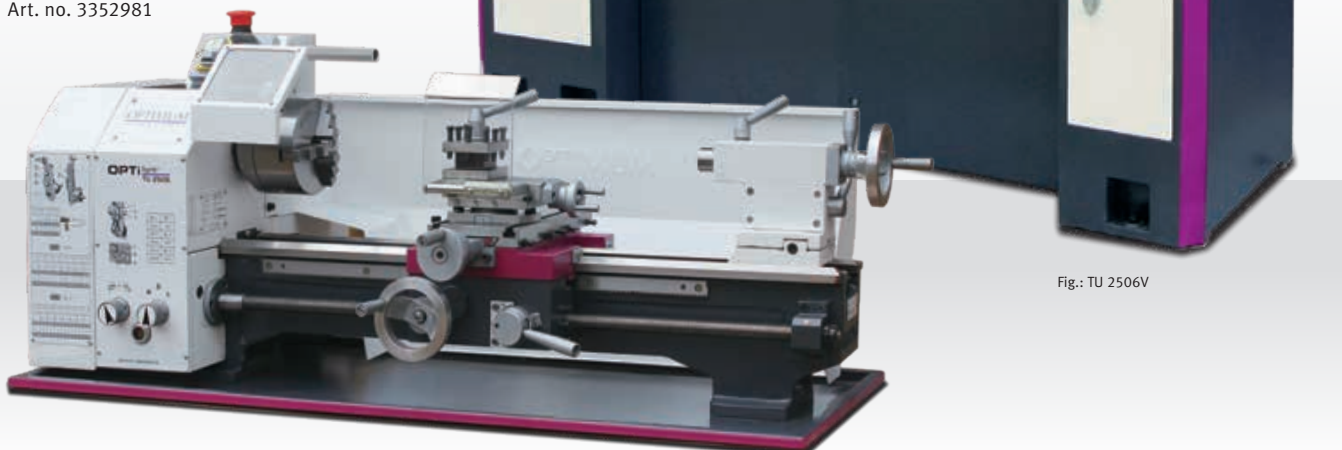

Fig.: TU 2506V

Fig.: TU 2506

Technical specifications, accessories and dimensions

Model	TU 2506	TU 2506V*
Article no. (230 V)	3425001	3425006
Article no. (400 V)	3425003	

Technical specifications		
Electrical connection	230 V / 1 Ph ~ 50 Hz 400 V / 3 Ph ~ 50 Hz	230 V / 1 Ph ~ 50 Hz
Drive motor	750 W	1.5 kW
Spindle		
Spindle taper	MT 4	
Spindle seat	Short taper	
Spindle bore, bar passage diameter	Ø 26 mm	
Quadruple tool holder mounting height	max. 13 mm	
Work area		
Centre height	125 mm	
Centre width	550 mm	
Swing Ø over machine bed	250 mm	
Bed width	135 mm	
Speed range		
Spindle speed	125 - 2 000 rpm	30 - 4 000 rpm 4 speeds
Number of speeds	6 speeds	Electronically controlled
Travel		
Top slide travel	70 mm	
Cross slide travel	110 mm	
Feeds and pitches		
Longitudinal feed within the range	0.07 - 0.4 mm/rev (6 feeds)	
Pitch - metric in range	0.2 - 4 mm/rev (21 pitches)	
Pitch - inch in range	56 - 8 turns/inch (21 pitches)	
Tailstock		
Tailstock seat	MT 2	
Tailstock quill diameter/stroke	30 mm / 65 mm	
Dimensions		
Length x width x height	1 250 x 585 x 475 mm	1 250 x 650 x 420 mm
Weight	125 kg	

Lathe chucks and accessories	Art no.
Four-jaw lathe chuck Ø 125 mm, individual clamping (Chuck flange 3441312 required)	3442874
Four-jaw lathe chuck Ø 125 mm, centre clamping (Chuck flange 3441312 required)	3442812
Chuck flange lathe chuck Ø 125 mm (lathe chuck 3442874/3442812)	3441312
Planar clamping disc Ø 240 mm	3441352
› Information about lathe chucks from page 184	

Accessories	Art no.
Steady rest passageway max. Ø 50 mm	3441315
Follow rest passageway max. Ø 34 mm	3441310
Quick change tool holder SWH 1-A	3384301
Factory assembly SWH 1-A	9000401
Spare tool holder 20 x 90 type D for square chisels	3384302
Spare tool holder 20 x 85 type H for round chisels	3384321
Lathe tool set 10 mm, 11-part (see page 189)	3441602
Lathe tool set 12 mm, 11-part (see page 189)	3441603
Lathe tool set 12 mm, 5-part "Made in Germany"	3441212
Collet kit ER 32, 3 - 20 mm	3441122
Collet chuck ER 25, cylindrical	3441305
Collet chuck ER 32, short taper	3441306
› More accessories for lathes from page 188	

*Important information on transport surcharges and „General notes on operating our machines“ on page 253

**The lathe (frequency converter) complies with the DIN EN 55011 standard: class C3 - Note for operation with frequency converter on page 253

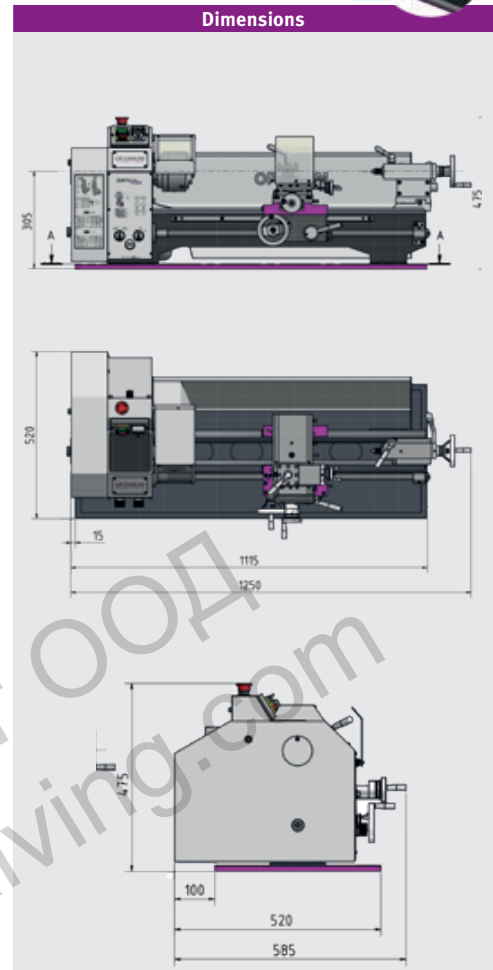

Scope of supply
› Three-jaw lathe chuck Ø 125 mm,
› Centre clamping
› Fixed centre MT 2 and MT 4
› Splashguard
› Chip tray
› HSS lathe tools
› Quadruple tool holder
› Replaceable gear set
› Operating tool

Accessories	Art no.
	
Digital position display DRO 5 incl. 3 magnetic sensors	3383975
Magnetic strip length 1 100 mm	3383978
Factory assembly	9000420
› Information about position display on page 252	